

## Bujes de fijación SSE-SW

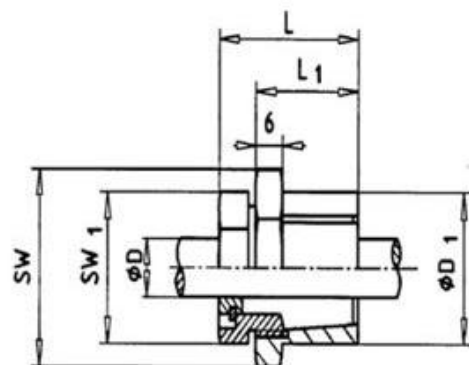
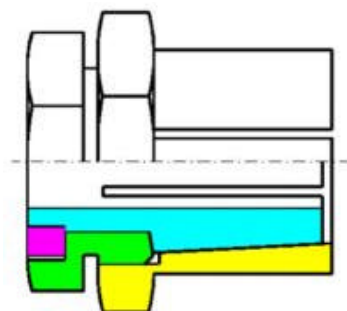

## SSE-SW

Tamaño	01	02	03	04	05	06	07
<b>Dimensiones en mm</b>							
<b>L</b>	32,5	36,5	40,5	45,5	48,5	52,5	54,5
<b>L1</b>	25	28	31	35	39	43	45
<b>ØD ISO H7</b>	06 - 12	12 - 15	15 - 20	20 - 25	25 - 30	30 - 35	35 - 40
<b>ØD1 ISO h6</b>	24	26	36	42	47	52	56
<b>ØSW1 6-Kt</b>	24	27	36	46	50	60	65
<b>ØSW 6-Kt</b>	27	27	41	46	50	60	65
<b>Llave de apriete</b>	DIN 3110-Llave fija						
<b>Datos técnicos</b>							
<b>Par de apriete tornillos Nm</b>	35	50	70	120	180	300	430
<b>Par nominal Nm</b>	10-48	48-75	75-120	125-180	200-340	340-480	480-630

**Material:** Acero (acero inoxidable bajo pedido)

**Ejemplo de pedido:** SSE-SW 03 18H7

Tipo	Tamaño	Diámetro del eje
SSE-SW	03	18H7

Otros largos bajo pedido